

Product Code	Description
HC2712L-2	16AX 2 Gang 2 Way Switch with Indicator Light



HC2712L-2

Technical Specification



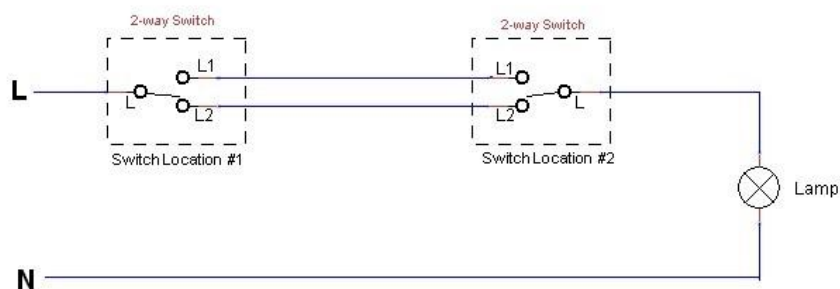

- Rated Voltage: 250VAC, 50/60Hz
- Rated Current: 16AX
- Recommended wire size:
2.5mm² - 4mm²
- Isolating Gap Contact: 3mm nominal
- Contact Material: Silver-Nickel Alloy
- Operating Temperature:
-5°C to +40°C
- IP Rating: IP2X
- No. of operations:
40,000 operation at 16 Amp.
- Dimensions: 86 x 86 x 10mm (WxHxD)
- Fix Center: 60.3mm
- Fix Screw: M3.5 x 0.6 x 30mm±
- Mounting box: >25mm depth
 - R1150, flush mounting, plastic (80 x 80 x 48.4mm) (WxHxD)
 - M1247, flush mounting, metal (79 x 73 x 47mm) (WxHxD)
- Comply to standards:
 - BS EN 60669-1
 - IEC 60669-1
 - GB/T 16915.1

Typical 2-way Switch Connection

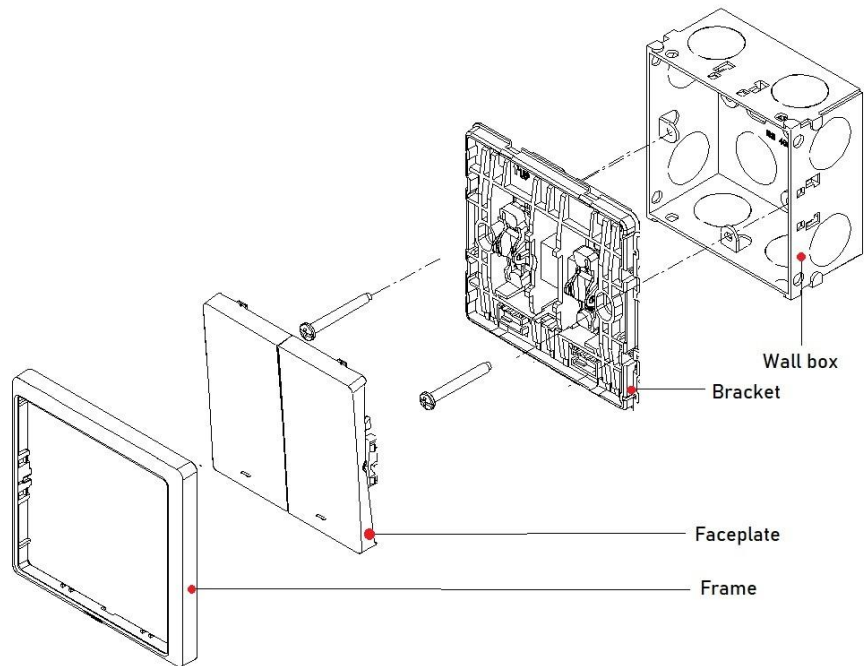

Installation Method:



Product Code	Colour
HC2712L-2	 White
HC2712L-2-SBL	 Matt Black (SBL)
HC2712L-2-PS7	 Dark Champagne (PS7)
HC2712L-2-ST5	 Champagne Grey (ST5)
<i>For other colour, please contact T&J Sales representative</i>	

